



Effect of Reinforced Concrete Jacketing on Axial Load Capacity of Reinforced Concrete Column

Praveen Anand^{a*}, Ajay Kumar Sinha^b

^a Research Scholar, Department of Civil Engineering, National Institute of Technology, Bihar, Patna, 800005, India.

^b Professor, Department of Civil Engineering, National Institute of Technology, Bihar, Patna, 800005, India.

Received 28 February 2020; Accepted 29 May 2020

Abstract

Whenever a member of a structure becomes structurally deficient, it becomes vulnerable to the existing load and for the additional loads that it may be subjected to in the coming future. Since columns are the most important structural element, the structural retrofit of columns, relative to other structural elements is of prime importance. This study intends to investigate the performance and behaviour of an RC column jacketed with Reinforced Concrete columns under axial loads. The objective of this paper is to find out the efficiency of RC jacket in enhancing the strength of an existing RC column. A mathematical design based upon Indian Standards codes has been designed to identify the behaviour of jacketed RC columns. This has been followed by a finite element based numerical simulation using the same material properties as used in the process of designing. The simulation has been done in ABAQUS software with appropriate contact modelling. The analytical model considers that there is no bond slippage between the existing and new concrete surface i.e. the bond between the existing and new concrete is assumed to be perfect. This perfect bond between the surfaces has been modelled by using appropriate constraints in ABAQUS software. The finite element models show fair agreement with the designed values in terms of ultimate capacity and failure mode. The load bearing capacity enhancement of the RC jacketed column has been found to increase substantially. The enhancement capacity results obtained from the finite element software differs about 16-25% from the design values.

Keywords: Retrofitting; Strengthening; Jacketing, Reinforced Concrete (RC) Column; ABAQUS.

1. Introduction

In order to prevent the disaster associated with the buildings due to additional floor loads or due to inadequate designs, the existing buildings sometimes need to be retrofitted. Retrofitting means repair, renovation and strengthening of the existing structures to make them more resilient or fit for the desired purpose. Nowadays retrofitting, repairing and restoring have become one of the most important aspects for structural engineering community and over the year's engineers have used different methods and techniques to retrofit existing structures. Several researches and studies on enhancing the strength and usability of the existing Reinforced Concrete Column have been done. The studies performed on Strengthening and Rehabilitation by Reinforced Concrete Jacketing technique considered different practical aspects like surface interface preparation, adding longitudinal reinforcements and shear stirrups spacing [1]. In order to study the main purpose of Jacketing and making some technical considerations into it several provisions and detail were made for Concrete and steel jacketing as well for both column and beam member.

* Corresponding author: praveen.ce16@nitp.ac.in

 <http://dx.doi.org/10.28991/cej-2020-03091546>



© 2020 by the authors. Licensee C.E.J, Tehran, Iran. This article is an open access article distributed under the terms and conditions of the Creative Commons Attribution (CC-BY) license (<http://creativecommons.org/licenses/by/4.0/>).

The details regarding properties of the jacket, minimum width of the jacket, minimum area of longitudinal and transverse reinforcements was given [2, 3]. The behaviour and failure load of strengthened columns with steel jacket was experimentally investigated considering different variables i.e. the shape of the main strengthening systems, size and number of batten plates, thickness of the jacket, aspect ratio of the column etc. [4, 5]. Achillopoulou et al. made an important study depicting the force transfer between the interface of existing RC columns and the jacket. They concluded that the initial damage of the existing column affects the load carrying capacity of the jacket. The results also contributed in finding the factors responsible for the slip at interface [6].

Furthermore, the behaviour of RC column which is in compression and externally strengthened with RC jacket has been analysed and also the effectiveness of the cross section of the jacket member in confining the concrete core have been studied [7]. The importance and choice of the accurate strengthening material used have also been highlighted. Experimental investigation of the effectiveness of concrete jacket when strengthening RC columns was done by Vandoros et al. [8]. Vandoros et al. considered three different techniques for construction of jacket (a) welding the ends of jacket stirrup and pouring concrete in the jacket (b) welding the ends of jacket stirrup, dowel placement at the interface and pouring concrete in the jacket and (c) bent down bars that connected the jacket bars to the longitudinal bars of the original column and a shotcrete jacket. Secondly, for the purpose of comparison, the results of two specimens which were strengthened by using CFRPs was presented. Vandoros et al. concluded a substantial decrease in ductility and the dissipated energy capacity by RC jacketing as compared to the other strengthening techniques. Comparative analysis of jacketing the existing column with CFRP and FRCC was also done by Zoppo et al. in which the FRCC jacketing proved to be a very sound retrofitting strategy for the existing columns [9].

The work carried out over 15 years by Vandoros and Dritsos (2008) was taken forward by Dritsos and Moseley, [10]. In order to correlate the behaviour of a jacketed specimen with that of a respective monolithic specimen, appropriate monolithic coefficients, that correlated the stiffness, the displacement and the strength at yield and failure of jacketed columns with that of respective equivalent monolithic columns were developed. They noted that with the use of such coefficients, Finite element analysis can be avoided and it becomes easy for engineers to apply in practical situations using conventional concrete design procedures. The uncertainties regarding the behaviour of the strengthened column specimen, particularly at the interface between the existing (old) and new concrete was examined by Lampropoulos et al. [11] with Finite element method under monotonic and cyclic loading. The analytical results were compared with the available experimental results from Vandoros and Dritsos (2008). According to him assumption for a perfect bond between the existing (old) and new concrete results in an eminent overestimation of the response of the strengthened columns. He also gave a conclusion that the shrinkage of new concrete to the jacket cannot be ignored. In order to investigate the repair and strengthening techniques, four RC column unit were tested subjected to simulated seismic loading [12]. The columns were tested, repaired and strengthened by jacketing and retested. The jacketing consisted of 100 mm (3.94 in) thickness of added reinforced concrete. The as-built columns showed low availability of ductility and significant degradation in strength during testing, whereas the jacketed column performed in a ductile manner with increased strength and much decrease in strength degradation.

The study on strengthening and retrofitting the column and joints with the application of high performance fibre reinforced concrete jacket was done by Beschi et al. [13]. With the investigation of this technique they were able to conclude that the technique improves the bearing capacity and the ductility of the existing structures significantly.

Investigation on the effect of jacketing on flexural strength and performance of the columns and beams has also been done in the past [14, 15]. Firstly, the interface between the old and new concrete were tested by slant shear tests. Secondly the specimens were tested to study the strength and thirdly beam-column joint assembly were tested to study the ductility and energy dissipation. The use of self-compacting concrete was and roughening the surface of the existing column and beam by motorised wire brush was found to be satisfactory. A significant improvement in the moment carrying capacity of the retrofitted column was found and ductility is also retained.

An attempt to strengthen the existing damaged RC columns using thin Concrete jackets was made [16]. Using 25 mm and 35 mm jackets thickness improves the ultimate load carrying capacity considerably. In this study we have designed a RC column based upon the provisions of existing Indian Standards codes. Thereafter the RC jacket of specified thickness has been designed which is also based upon the IS Codes. The study examines the effectiveness of a specified jacket thickness used for the strengthening of the existing RC column and its effect on increasing the axial load carrying capacity.

2. Materials and Methods

In this study a square RC column subjected to an axial load has been designed based upon IS 456 Standards (2000) [17], and the RC jacket has been designed as per the provisions mentioned in BIS (2013) [18]. The percentage increase in the load carrying capacity has been found. Moreover, the same column and the jacket design with exact reinforcement detailing has been modelled in a FEM software ABAQUS 6.14 to match the closeness of the simulation and mathematical calculation.

The study has been carried out for a square RC column whose jacketing has to be done has been designed with Limit State Method in accordance with IS 456-2000 recommendations. Therefore, all the assumptions associated in the analysis design by LSM are applicable here also. The primary aim of designing the column is to find its ultimate load carrying capacity and then design its jacket to find out the percentage increase in the load carrying capacity of the column after jacketing. Jacket is designed in accordance with the provisions made in IS 15988-2013. The same design will be modelled in a finite element software ABAQUS and the difference between the design values and simulation results will be observed.

2.1. Determination of Load Carrying Capacity

A RC column of 3m length having a cross section of 300×300 mm with 1% area of reinforcement has been designed and its load carrying capacity has been calculated as per the limit state method. The strength of the column is determined from the following equation with respect to IS 456:2000 section 39.3:

$$P = 0.4 \times f_{ck} \times A_c + 0.67 \times f_y \times A_{sc} \tag{1}$$

Where; f_{ck} : Characteristics compressive strength of the concrete (20 MPa); f_y : Characteristic strength of compressive reinforcement (415 MPa); A_g : Gross area of the column (90000 mm²); A_{sc} : Area of longitudinal reinforcement required for the column (1% of $A_g = 900 \text{ mm}^2$); A_c : Area of concrete ($A_g - A_{sc} = 89100 \text{ mm}^2$); Reinforcement provided = 8 - 12 Φ , i.e. 905 mm² > 900 mm².

$$P = 0.4 \times 20 \times 89100 + 0.67 \times 415 \times 900 = 963.045 \text{ KN}$$

Using a factor of safety as 1.5, the ultimate load carrying capacity (P_u) will be:

$$P_u = 1.5 \times 963.045 = 1444.56 \text{ KN.}$$

2.2. Design of the Jacket

The design for the jacketing of the columns is based on the provisions and specifications made in IS 15988:2013. The minimum specifications required for jacketing a column are:

1. Strength of the new materials that shall be used should be at least equal to or greater than those of the existing Column. The strength of new concrete shall be greater than that of the existing concrete by at least 5 MPa.
2. For columns where no additional longitudinal reinforcement is required, at least 12 Φ bars should be provided at the four corners with 8 Φ ties @ 100 c/c spacing.
3. Minimum jacket thickness that shall be provided is 100 mm.
4. Minimum diameter of ties that shall be provided is 8 mm and not less than one-third of the longitudinal bar diameter.
5. The spacing of vertical ties should not exceed 200 mm. If possible, the spacing of ties shall not be greater than the thickness of the jacket or 200 mm whichever is less.

The design for the jacketing of the columns is based on the provisions and specifications made in IS 15988:2013.

$$A_c = A_g - A_{sc} \tag{2}$$

But $A_{sc} = 0.01A_g$; Therefore, $A_c = 0.99A_g$ So:

$$1444.56 \times 1000 = 0.4 \times 25 \times 0.99A_g + 0.67 \times 415 \times 0.01 A_g \rightarrow A_g = 113920 \text{ mm}^2$$

Since the cross section is a square, therefore: $B = D = \sqrt{113920 \text{ mm}^2} = 338 \text{ mm}$; so, let $B = D = 350 \text{ mm}$.

Therefore, thickness of the jacket = $(350 - 300)/2 = 25 \text{ mm}$.

But According to IS: 15988-2013, Minimum thickness of the jacket should be 100 mm; i.e. $B = D = 500 \text{ mm}$.

$$A_{gj} = (500 \times 500) - (300 \times 300) = 160000 \text{ mm}^2$$

$$A_{scj} = 0.01A_{gj} = 1600 \text{ mm}^2$$

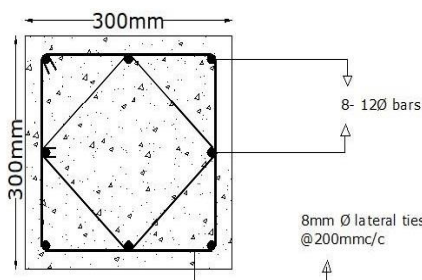

Figure 1. Reinforcement detailing of initial column

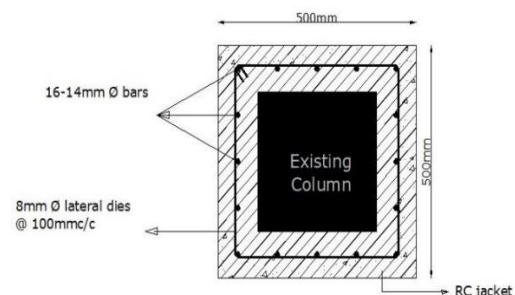

Figure 2. Reinforcement detailing of jacket

But as per IS 15988, clause 8.5.1.1 (e); $A_{scj} = (4/3) \times A_{scj}$ obtained (3) = $1.33 \times 1600 = 2128 \text{ mm}^2$. So, providing 16-14Φ bar for the main reinforcements (Figure 2).

$$A_{sc} \text{ Provided} = 2463 \text{ mm}^2 > 2128 \text{ mm}^2.$$

$$(P_u) \text{ Jacket} = 0.4 \times 25 \times 157537 + 0.67 \times 415 \times 2463 = 2260.20 \text{ KN}$$

$$\text{Therefore; } (P_u) \text{ Jacketed column} = P_u + (P_u) \text{ Jacket} = 1444.56 \text{ KN} + 2260.20 \text{ KN} = 3704.76 \text{ KN}.$$

$$\text{Hence, percentage increase in load carrying capacity is } = ((P_u) \text{ Jacketed} - P_u) / P_u \times 100 = 156.46\%.$$

3. Modelling and Simulation

In order to develop a method for validating the mathematical calculations and design, the same column with exact reinforcement details has been modelled in a Finite Element software ABAQUS 6.14. ABAQUS provides a very fine element library to model isotropic elasticity with isotropic tensile and compressive plasticity to represent the behaviour of concrete. The most fundamental operation to begin with was creation of parts. Different parts like column, reinforcement and jacket parts have been created. All parts have been modelled in three dimensions by taking modelling space shell planar and type deformable. A deformable part is a part that can be deformed under applied load. The properties of the materials have been defined and assigned using the property module. The Concrete-Damaged Plasticity model (CDP) was used for the definition of concrete in the plastic range. The plastic model damaged by cement provides a general capacity for modelling the concrete. The plasticity model of the damaged concrete is based on the assumption that the concrete is subject to arbitrary loading conditions. The longitudinal and transverse steel reinforcement behaviour have been defined as an elastic-plastic material. The section for assigning property of concrete has been taken solid and homogeneous while for frame steel section has been taken as beam.

Table 1. Material Properties

Material Name	Density (Kg/m ³)	Elasticity (MPa)	Poisson's Ratio	Yield Stress	
				Compression (MPa)	Tension (MPa)
1. Concrete					
A. Column	2400	20000	0.13	20	3.15
B. Jacket	2400	20000	0.13	25	3.5
2. Steel	7850	200000	0.3	415	

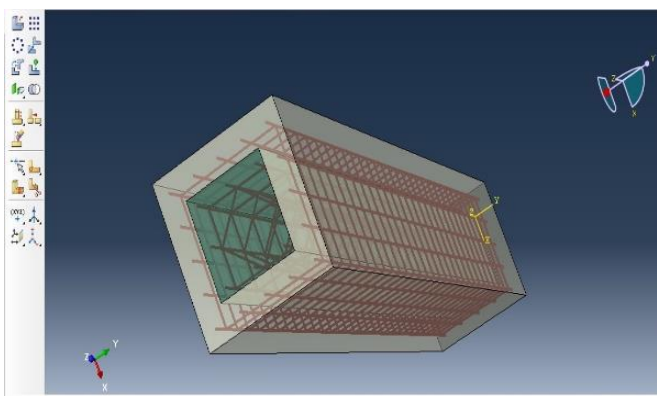

Figure 3. Assembling the parts and instances

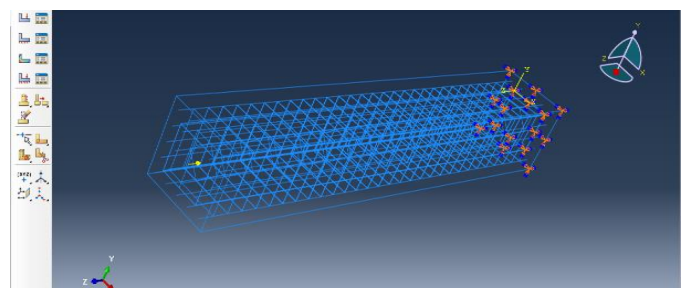

Figure 4. Loading and boundary conditions

The parts and their instances are positioned properly to create an Assembly and define the geometry of the finished model and to ensure a single coordinate system. Figure 3 displays a Finite element model assembly and the coordinate system of the column modelled for analysis. For the present model the element shape of the mesh assigned is “HEX” and the technique used is “Structured”. In the structured model, a 3-Dimensional eight- node linear brick reduced integration C3D8R element was used for concrete and a two- node linear beam B31 element was used for steel. In the analysis model, the column is fixed at one end and free at the other. The axial load is applied at the free end as shown in Figure 4. The load and boundary conditions are the objects which are STEP dependent. The load has been created in the STEP 1. Since STEP 1 is a General Static, the magnitude of load is ramped up over the course of STEP. Ramped option changes the value of loading at a steady rate (User, C.A.E ABAQUS 6.14) [19].

4. Simulation Plots and Variation

The performance of the column before jacketing and after jacketing has been examined and plotted. Plots like Load-Displacement plot has been plotted with the help of ABAQUS X-Y tool.

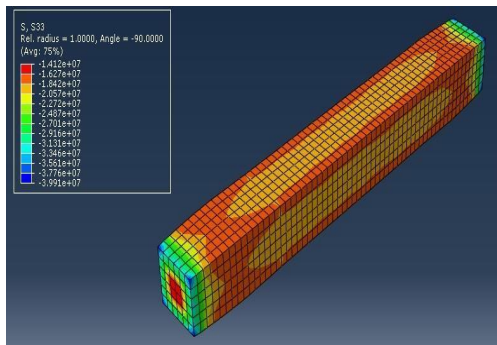

Figure 5. Stress Distribution of the initial column

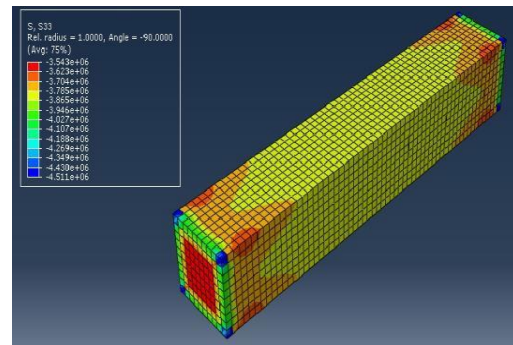

Figure 6. Stress Distribution of the jacketed column

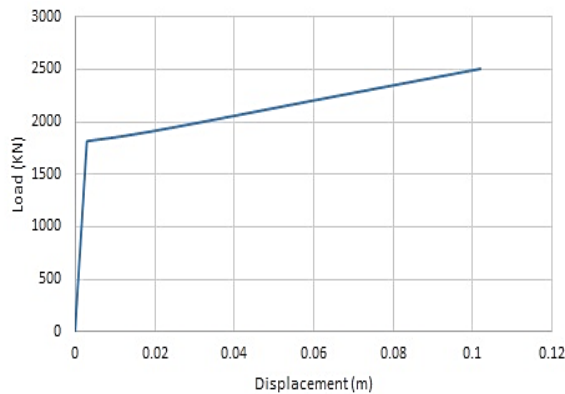

Figure 7. Load vs. Displacement of initial column

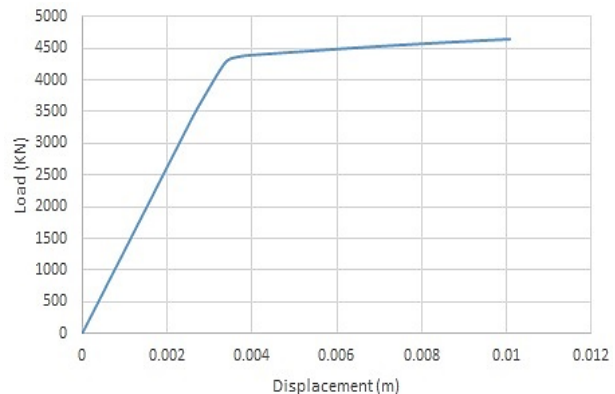

Figure 8. Load vs. Displacement of the jacketed column

The stress distribution pattern of the jacketed column is more uniform as compared to the initial column. From the above plot of load vs. displacement curves it has been seen that the ultimate load of the initial column is 1800 KN. After this point, the displacement starts to increase at a much higher rate with little change in applied load. Similar to the previous plot, the ultimate load from the load vs. displacement curve of the jacketed column is 4320 KN. After this point, the displacement starts to increase at a much higher rate with little change in applied load.

5. Results and Discussion

The data and results of this study is presented in tabular form. The values of ultimate load capacity have been obtained from the simulation plots.

Table 2. Percentage increase in strength after jacketing

Load Carrying Capacity	Initial column	Jacketed column	Percentage increase in strength
As per Design (KN)	1444.56	3704.76	156.46%
As per Simulation (KN)	1800	4320	140%

Table 3. Percentage difference in the results obtained from design and simulation

Load carrying capacity	As per Design (KN)	As per Simulation (KN)	Percentage difference
1. Initial column	1444.56	1800	24.60%
2. Jacketed column	3704.76	4320	16.60%

From the above results it can be pointed out that the percentage increase in axial load carrying capacity as per design is more than that obtained after simulation in ABAQUS. The basic reason for this difference is the effect of bonding between the old existing concrete surface and the new jacket surface. For the design process the load carrying capacity of the initial column and the jacket portion were calculated separately and they were summed up assuming a perfect bond between the old and new surfaces. While during the simulation in ABAQUS, surface to surface bond between old and new concrete was established using TIE constraint. Since the analysis is based on the assumption of a 100 percent bond at the interface, the perfect bond between the jacket and the column was simulated by merging the nodes of existing column with the nodes of the jacket at the interface.

6. Conclusion

Strengthening of column in this study was an attempt to increase the load carrying capacity of it in an existing building that needs to be retrofitted to fulfil the desired purpose. The strength of the column member subjected to concentrically axial compressive load increases significantly after RC jacketing. As per results mentioned in Table 2, the increase in the load carrying capacity of the jacketed column as per design is 156.46% while it is 140% as per simulation done in ABAQUS. From the experiment performed in the past, the increase in load carrying capacity was observed to be around 110% under uniaxial load [14] for 50 mm jacket thickness. So the difference and large increase in the load carrying capacity for the present study may be attributed to the use of thick jackets around the four sides which is 100mm as well as the TIE constraint used in the modelling which imparts perfect surface to surface bond between the existing concrete and the jacket. The difference between the design and values and the values obtained after simulation varies between 16.60 to 24.60%. The results of this study will be helpful in comparing the overall efficiency of this technique with that of the other jacketing techniques that are available. Further, appropriate technique may be adopted depending upon Carpet area available, Cost analysis also needs to be done prior to choosing any of the methods.

7. Conflicts of Interest

The authors declare no conflict of interest.

8. References

- [1] Júlio, E S, F Branco, and V D Silva. "Structural Rehabilitation of Columns with Reinforced Concrete Jacketing." *Progress in Structural Engineering and Materials* 5, no. 1 (January 2003): 29–37. doi:10.1002/pse.140.
- [2] Waghmare, Shri Pravin B. "Materials and jacketing technique for retrofitting of structures." *International Journal of Advanced Engineering Research and Studies* 1, no. 1 (2011): 15-19.
- [3] Raza, Saim, Muhammad K. I. Khan, Scott J. Menegon, Hing-Ho Tsang, and John L. Wilson. "Strengthening and Repair of Reinforced Concrete Columns by Jacketing: State-of-the-Art Review." *Sustainability* 11, no. 11 (June 9, 2019): 3208. doi:10.3390/su11113208.
- [4] Belal, Mahmoud F., Hatem M. Mohamed, and Sherif A. Morad. "Behavior of Reinforced Concrete Columns Strengthened by Steel Jacket." *HBRC Journal* 11, no. 2 (August 2015): 201–212. doi:10.1016/j.hbrcj.2014.05.002.
- [5] Sakino, Kenji, and Yuping Sun. "Steel jacketing for improvement of column strength and ductility." In *Proceeding of 12th WCEE Conference*. 2000.
- [6] Achillopoulou, D. V., T. C. Rousakis, and A. I. Karabinis. "Force transfer between existing concrete columns with reinforced concrete jackets subjected to axial loading." *Proceeding of 15th WCEE Conference*. 2012.
- [7] Campione, G., M. Fossetti, C. Giacchino, and G. Minafò. "RC Columns Externally Strengthened with RC Jackets." *Materials and Structures* 47, no. 10 (July 19, 2013): 1715–1728. doi:10.1617/s11527-013-0146-x.
- [8] Vadoros, Konstantinos G., and Stephanos E. Dritsos. "Concrete Jacket Construction Detail Effectiveness When Strengthening RC Columns." *Construction and Building Materials* 22, no. 3 (March 2008): 264–276. doi:10.1016/j.conbuildmat.2006.08.019.
- [9] Del Zoppo, Marta, Marco Di Ludovico, Alberto Balsamo, and Andrea Prota. "Comparative Analysis of Existing RC Columns Jacketed with CFRP or FRCC." *Polymers* 10, no. 4 (March 24, 2018): 361. doi:10.3390/polym10040361.
- [10] Dritsos, Stephanos, and Jon Moseley. "Monolithic Coefficient Design Values for Seismically Strengthening RC Columns with Jackets." *Ce/papers* 3, no. 2 (April 2019): 172–176. doi:10.1002/cepa.971.
- [11] Lampropoulos, A. P., and S. E. Dritsos. "Modeling of RC Columns Strengthened with RC Jackets." *Earthquake Engineering & Structural Dynamics* 40, no. 15 (April 29, 2011): 1689–1705. doi:10.1002/eqe.1109.
- [12] "Seismic Load Tests on Reinforced Concrete Columns Strengthened by Jacketing." *ACI Structural Journal* 91, no. 2 (1994). doi:10.14359/4593.
- [13] Beschi, C., A. Meda, and P. Riva. "Column and Joint Retrofitting with High Performance Fiber Reinforced Concrete Jacketing." *Journal of Earthquake Engineering* 15, no. 7 (September 2011): 989–1014. doi:10.1080/13632469.2011.552167.
- [14] Kaliyaperumal, Gnanasekaran, and Amlan Kumar Sengupta. "Seismic retrofit of columns in buildings for flexure using concrete jacket." *ISET Journal of Earthquake Technology* 46, no. 2 (2009): 77-107.
- [15] Narayanan, VT Badari, Amlan Kumar Sengupta, and SR Satish Kumar. "Seismic retrofit of beams in buildings for flexure using concrete jacket." *ISET journal of Earthquake Technology* 46, no. 1-2, (2012):1-22.

- [16] Tayeh, Bassam A., Mohammed Abu Naja, Samir Shihada, and Mohammed Arafa. "Repairing and Strengthening of Damaged RC Columns Using Thin Concrete Jacketing." *Advances in Civil Engineering* 2019 (June 11, 2019): 1–16. doi:10.1155/2019/2987412.
- [17] Standard, Indian. "Plain and reinforced concrete-code of practice." New Delhi: Bureau of Indian Standards (2000).
- [18] BIS. IS 15988:2013 Seismic Evaluation and Strengthening of Existing Reinforced Concrete Buildings - Guidelines: pp. 1–25: (2013).
- [19] User, C. A. E. "ABAQUS 6.14 Analysis User Guide." Dassault System (2014).