



## Solar Energy for Traction of High Speed Rail Transportation: A Techno-economic Analysis

Cawas Phiroze Nazir <sup>a\*</sup>

<sup>a</sup> Consulting Engineer, 5A Dilkusha Street, Kolkata 700017, India.

Received 06 March 2019; Accepted 11 June 2019

### Abstract

To meet the growing expectation of traveling public, world railways are going ahead in a big way to introduce high speed trains. Electric railways require huge amounts of energy. Many rail networks run their own dedicated power plants. With a view to augment the capacity of the rail networks grid connection so as to make the railway self-reliant, a grid tied PV solar plant with battery storage has been proposed. The present concept is based on installing solar panels along the length of a HS rail network so that the ballast-less tracks could be used as energy carriers. Ballast less tracks require little or no maintenance, and the space along the tracks provides a large surface area on which arrays of PV modules can be mounted to generate electricity from sunlight. An example demonstrates that a 330 MW grid connected PV solar plant with battery storage for the Mumbai–Ahmedabad high speed rail link, generates electricity at  $\$1.67 \times 10^6$  /MW output and levelized electricity cost at 12.05 c/kWh. Net saving in tariff after payback period is about \$ 58 million per annum.

*Keywords:* HS Railways; Slab Track; Solar Plant; Battery Storage; Shinkansen.

### 1. Introduction

To meet the growing expectation of traveling public, railways worldwide are going ahead in a big way to introduce high-speed (HS) trains. Electric railways require huge amounts of energy. Many rail networks run their own dedicated power plants. To augment the capacity of the rail networks grid connection, the abundant solar energy available in nature can be harnessed and converted to electricity in a sustainable way. Recently, there have been a few articles dealing with the application of PV sources to railway network. In Hayashiya et al. (2012) studies the potential of using solar generation on platform roofs have been analyzed [1]. The feasibility of a fixed PV system with battery storage was studied for urban rail transit [2]. Another feasibility study was made for rail coaches with rooftop solar systems [3]. Ciccarelli et al (2018) have demonstrated the technical feasibility of integrating a PV power plant in order to supply a railway system [4]. In Chino (2009) research, a plan is proposed to introduce solar powered Bullet trains in Arizona with power generated by solar panels mounted on a solar canopy [5]. Indian Railways (IR) has realized the potential of using the rail corridor to produce solar energy and has installed solar panels on the roof of 250 local trains [6]. A source of large surface areas for solar photovoltaic (PV) generation that has been largely overlooked is the space along the rails. Installing PV modules at these locations would transform every km of railway line into a photovoltaic field, able to produce solar energy, which could be used to provide electricity for traction. For this to be feasible, it is important that the PV panels are not disturbed during maintenance of sleepers. The use of concrete slab track for high speed (HS) railways provides an ideal platform for locating these panels. Here the ballast is replaced with a rigid concrete track slab

\* Corresponding author: [cpnazir@gmail.com](mailto:cpnazir@gmail.com)

 <http://dx.doi.org/10.28991/cej-2019-03091353>



© 2019 by the authors. Licensee C.E.J, Tehran, Iran. This article is an open access article distributed under the terms and conditions of the Creative Commons Attribution (CC-BY) license (<http://creativecommons.org/licenses/by/4.0/>).

which transfers the load and provides track stability [7]. The increased railway speed nowadays is making the slab track concept more attractive than ever before. The current paper aims to address the potential and cost effectiveness of a grid connected solar power plant with battery storage to meet the peak demand of electricity for the Mumbai-Ahmedabad HS corridor [8]. Results demonstrate the effectiveness of the new design in terms of investment and operation /maintenance costs.

## 2. Overall Concepts

As HS trains have high operational costs, it was sought to reduce the cost of energy consumed by supplementing the grid with a renewable energy source such as solar power. The overall aim was to demonstrate the viability of a PV solar cum battery storage power plant that could produce steady power for a HS rail link. This plant could augment the energy consumption during peak traveling period and tremendously improve the financial viability of Railways in a big way. The East Japan Railway has already installed a battery system to reduce energy supply from traction sub-station by about 5-8% [9]. In another example [10], Hitachi in collaboration with Kyushu have developed a battery powered train charged from AC overhead lines to support through service on electrified sections. Current levels of dependence on fossil fuels, the need of reducing the carbon emissions associated with energy use, and the prospect of developing new and innovative technologies could make this an increasingly attractive solution. The present concept is based on installing solar panels along the length of a HS rail network so that the ballast-less tracks could be used as energy carriers. Experience of German networks indicates there is almost zero maintenance required for ballast less tracks [11]. As there is no need for tamping, ballast cleaning and track lining, solar panels can be installed without fear of disturbing them at regular intervals. Also, land along busy railway corridors are costly and hard to find. The PV system is combined with MWh battery storage. It is designed to have sufficient capacity to run the trains and charge the batteries. Battery based grid tie inverters can draw electrical power to and from the battery banks, as well as synchronize with the grid. Slab track systems have the capability to serve the high speed routes more efficiently than ballasted tracks mainly due to their high structural stability significantly lower need of maintenance, and lower life cycle, [7]. A typical plan and section of ballast-less tracks incorporating solar panels for the Shinkansen HS train is shown in Figure 1.

### 2.1. Mode of Operation

The PV system is installed as a grid interactive system since the main load is connected by grid and also, grid acts as a storage system for intermittent source of generation. A battery energy storage system (BESS) is also envisaged. The following schemes have been considered. a) Early in the day when PV is producing abundant power and when the grid is available, consumer loads will be fed from the solar system as well as the grid with a priority to solar PV system. When PV generation falls, automatic disconnection from solar side takes place and grid is connected to consumer AC load. b) In the evening, the battery energy storage system (BESS) that are used to store energy can discharge the stored electricity to meet the energy demands. The PV system is provided with enough capacity to charge the BESS during sunlight hours. c) When energy demands of the trains exceed design limits due to increased frequency, then power is drawn directly from the grid.

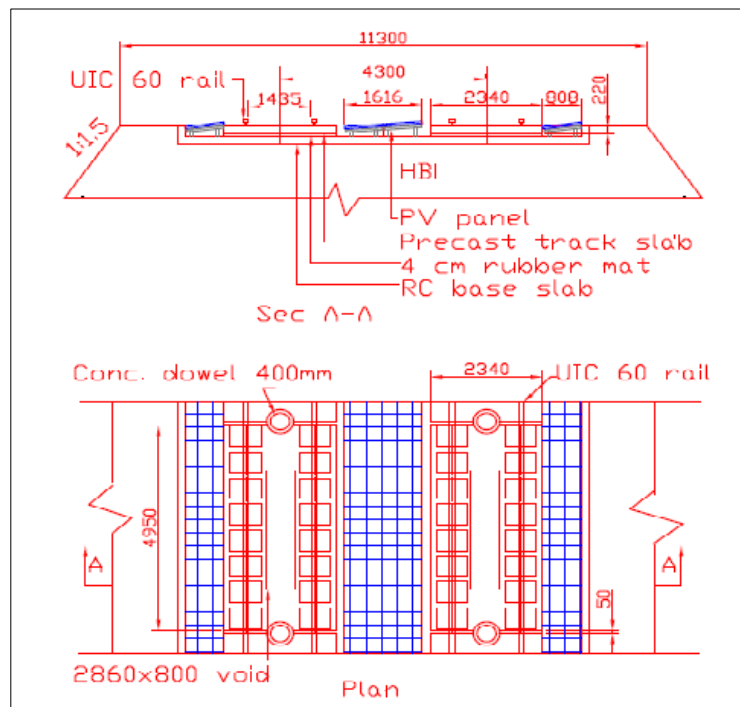

Figure 1. Shinkansen track slab

### 3. Design Overview

#### 3.1. Design of Slab Track Support

Track requirement for high speed traffic are very specific. Presently ballasted track is generally required for speeds upto 220 kmph and after that ballast-less tracks are used [12]. Slab track is a concrete surface that is replacing the standard ballasted track. The whole structure is mainly composed of five layers as shown in Figure 2. It consists of; sub grade, frost protective layer, hydraulically bonded bearing layer, concrete bearing layer and the rail, [13]. Ballast-less tracks are expected to provide the same degree of elasticity in all directions as is available in ballasted tracks. They should, a) Dampen the high frequency vibrations of the rail; and b) Provide a medium to distribute the on-coming loads and absorb the energy generated. Detail design of slab track support is outside the scope of this paper. PV panels are mounted on racks fixed to the concrete track bed. Generally a clearance of about 390 mm is available between top of rails and top of R.C. slab for mounting panels to be tilt mounted to a slope of about 10°. Rubber pads at base of mounting supports help reduce vibrations being transferred to the panels. There are no panels between rails and this permits mechanical maintenance of tracks. Further, air turbulence created by passing of trains prevents dust from settling on panels. The only modification required for the present technology is to extend the two ends of the reinforced concrete track bed to accommodate the solar panels see Figure 1.

#### 3.2. Design of Solar Power Plant

Design of solar power plant would require determining: a) type and array of PV panels, b) number and type of inserts to be provided in the concrete slab track for installing PV panels, c) size of inverters and, d) design of battery bank. Space on either side of tracks and the space between tracks provide a large surface area on which arrays of PV modules can be mounted to generate electricity from sunlight. A typical arrangement

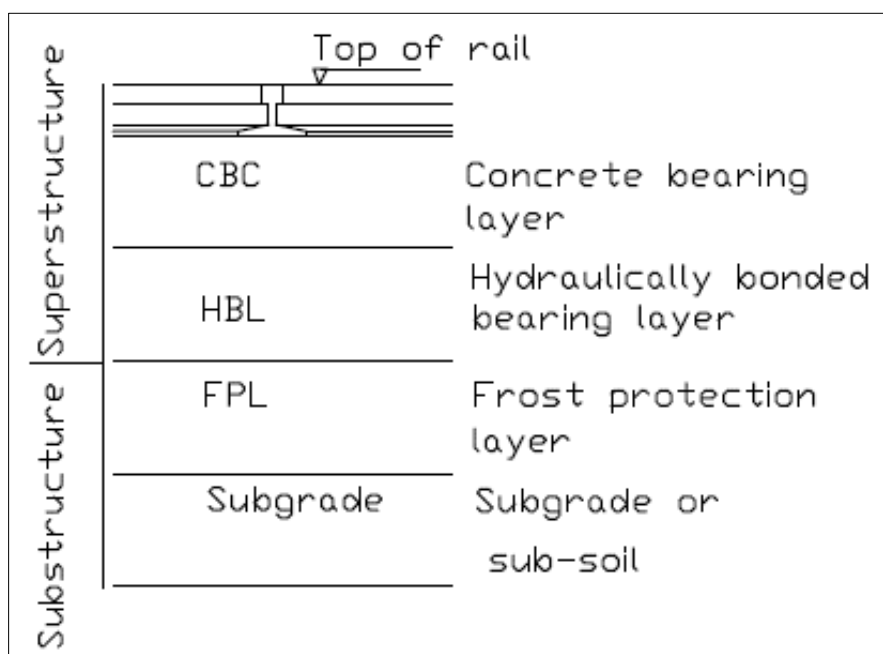

Figure 2. Usual construction profiles for track slab

Showing location of PV panels for the high speed (HS) track of the Mumbai- Ahmedabad line is shown in Fig.1. Hybrid solar systems utilize battery based grid-tie inverters. These devices can draw electrical power to and from the battery banks, as well as synchronize. They regulate the voltage and current received from the solar panels. The electrical charge is in DC form and is inverted from DC to AC for grid connection. In addition, incorporating the grid-tie inverters synchronize the phase and frequency of the current to fit the utility grid. The output voltage is also adjusted slightly higher than the grid voltage in order for excess electricity to flow outward to the grid. Use of pure sine wave inverters allow for suitable surge rating to cope with the start-up surges. The reliability and stability of the HS railways is ensured by addressing the power quality issues. To improve the power quality a variety of filters and compensation methods are used in the traction power supply system (TPSS) [14]. The PV system and BESS are connected to the TPSS. In order to investigate and address their practical impacts on TPSS, it may be necessary to carry out model based and measurement based analysis.

## 4. Example

Made as a practical design application is conceptual design and cost estimate for a grid connected PV solar plant with battery energy storage system (BESS) for the Mumbai –Ahmedabad high speed rail link. This link is based on the design adopted for the Shinkansen, Japan, and its salient features as indicated by Takatsu (2015) [15] are: a) total track length 508 km, (5.8 % underground); b) twin tracks with center to center spacing of 4.3m; c) track gauge 1435 mm; d) electrification, 2 x 25 kV AC, 50Hz; e) speed, 320 kmph; f) 10 cars with capacity of 750; g) trains assumed to run for 12 hours a day and g) ballast-less track system.

The basic plan for the power supply installation is as follows:

Incoming line- It is powered by double lines taken from the transmission network.

Feeding system –Single phase Ac, 50 Hz, 2×25 kV

Feeding voltage –The standard voltage of the system is 25 kV. The maximum allowable voltage is 30kV and minimum allowable voltage is 22.5 kV. In addition there is a minimum voltage of 20 kV for short duration [16]. Sub-station System - Traction substation (TSS) at 50 to 60 km. The solar cum battery installation proposed will comprise of a 191 MW PV station with solar modules installed along the length of the track which would transfer every km of railway line into a photovoltaic field. This will be combined with a BESS that has a 134 MW battery bank capable of storing 268 MWh. Power will be fed to the load during peak periods over duration of 12 hours. A typical block diagram of the plant is shown in Figure 3.

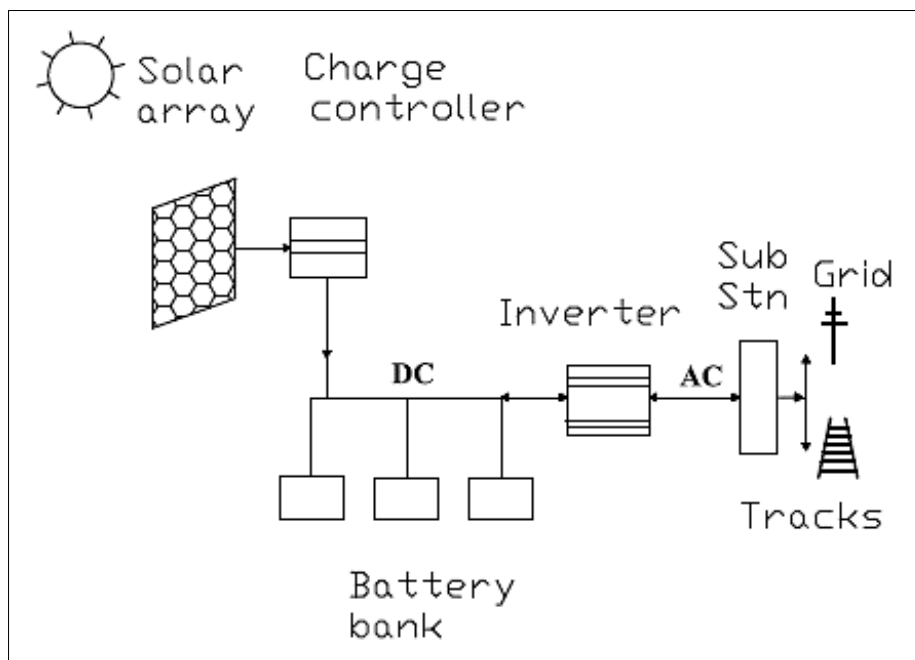

Figure 3. Block diagram of a PV system with battery back-up for HS traction

### 4.1. Design of Solar Photovoltaic Power Plant

#### 4.1.1. Panel Generation Factor

Panel generation factor (PGF) is a key element for estimating the number of panels required and is derived from the solar intensity and Sunshine hours [17].

$$PGF = \frac{\text{Solar irradiance}}{\text{Standard test condition irradiance}} \quad (1)$$

Average Solar irradiance assumed (near Surat), [18], 5.56 kWh/m<sup>2</sup>/day; Average daily sun hours assumed 8 hours. Then  $PGF = 5.56 \times 10^3 / 1000 = 5.56$

#### 4.1.2. Energy Demand of HS Rail Network

The Traction system of the Shinkansen high speed EMU's have 56 asynchronous motors of 305 kW each giving a rated power per train of 17,080 kW, [19]. Frequency of service planned is 2 trains running up and 2 trains running down every hour.

Energy trip for 1 hour =  $2 \times 2 \times 17080 = 68,320$  kWh.

Trains run for 12 hours/day, and energy consumed =  $12 \times 68320 = 819,840$  kWh/day.

Energy lost in system = 30%

Then energy required from PV modules =  $1.3 \times 819,840 = 1,065,792$  kWh/day.

It is assumed that the total energy from the PV plant over a period of 8 hours will be divided as follows: As trains runs for 12 hours, for first 8 hours of the day the energy

$8 \times 1065792 / 12 = 710528$  kWh/day will be supplied directly from the PV plant.

Balance of 355,264 kWh will be used to charge BESS, which is designed to discharge the PV generated electricity stored in batteries to match the specific 4 hour load period.

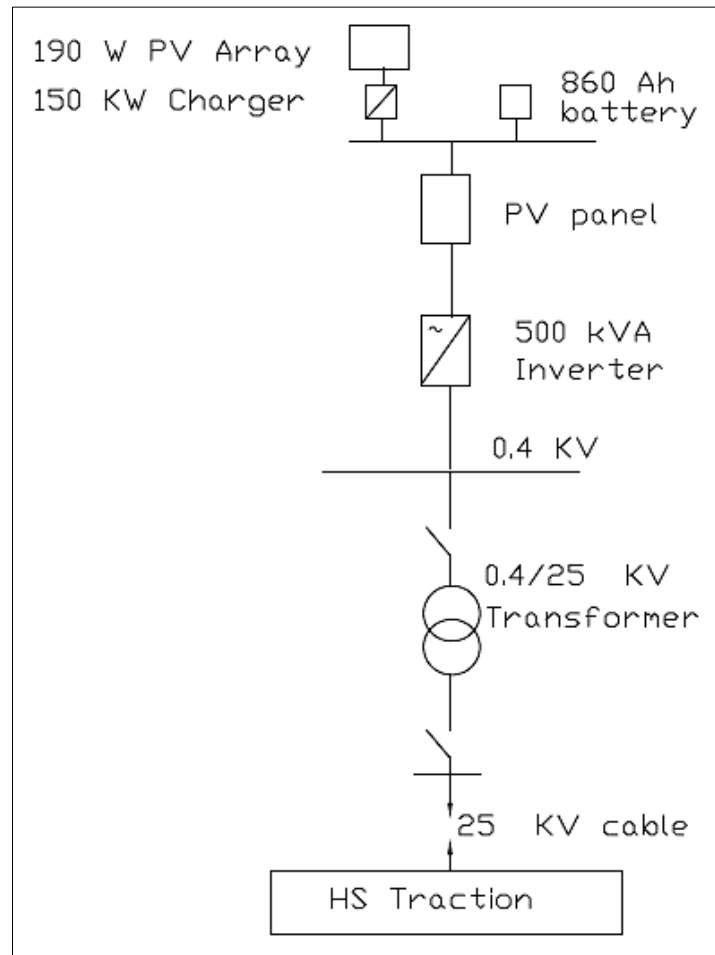

Figure 4. Single line diagram of transmission system

**4.1.3. Total Watt Peak Rating for PV Modules**

Total watt rating of the PV module is the ratio of the energy required to be produced from the solar panels and the panel generation factor.

$$\text{Total watt rating of the PV module} = \frac{\text{Energy required from PV modules}}{\text{Panel generation factor}} \tag{2}$$

Total watt rating of the PV module =  $1065792 / 5.56 = 191,689$  kW

**4.1.4. Number of PV Modules Required**

Standard solar panels from Solar land are employed in this study. PV module specifications are Solarland SLP1905-24 Mono crystalline [20]. Key specifications of the PV panels are shown in Table 1.

$$\text{Total number of PV panels required in the power plant} = \frac{\text{Total watt peak rating}}{\text{Peak rated output of the PV module}} \tag{3}$$

Number of PV modules =  $191689 \times 10^3 / 190 = 1008.8 \times 10^3 \cong 1,009,000$ .

**Table 1. Parameters of PV module**

Model Solarland SLP1905-24 Silver-Mono Solar panel	
Open circuit voltage	24 V DC
Output current	5.16 A DC
Maximum power	190 Wp
Dimensions	1580×808×35 mm

#### 4.1.5. Area Required for Mounting Panels

Area required for mounting panels is shown in Table 2. Net available track length = 481 km; Balance track length of (481 – 221) = 260 m can be utilized for installing additional; PV modules, the energy from which can be used for air conditioning of trains, stations, etc.

**Table 2. Area required for mounting panels**

Description	Data for length calculation
No. of PV modules required	1,009,000
Dimension of one PV module	0.808×1.58 m
Modules in an array connected in series	4
Total width of each PV array	3.32 m
No. of arrays in PV field	10090/4 = 252,250
No. of rows in solar field	252,250/4 = 63,062
Pitch distance	3.5 m
Length of solar field	63,062×(3.5) + 1.58 =, 220,719 ≅ 221,000 m
Less for a) underground tunnel and b) for 12 stations	21km 12×0.5 = 6 km
Actual length of track available	508 m
Net available	= 508 – (21 + 6) = 481 km

#### 4.1.6. Inverter Sizing

Size of inverter is based on peak watt requirement. Total wattage required is 191,689 kW. The inverter size should be 25-30 % bigger than the total wattage required, [21] Inverter size =  $1.3 \times 191689 = 249,196$  kW. A SAT Con Power gate Plus 500,480/3 Inverter is considered which has an in-built power point tracking system.

$$\text{Number of inverters required} = \frac{\text{Inverter size}}{\text{Rating of inverter}} \quad (4)$$

No of inverters =  $249,196 / 500 = 498.4 \cong 500$ . These inverters will be located about 1000 m apart at edge of track formation. Inverter wattage =  $500 \times 500 = 250,000$  kW = 250 MW

#### 4.1.7. Battery Sizing

The battery type recommended is deep cycle battery, model Crown 860Ah 48VDC. 41.28 kWh (16) battery bank. Wholesale solar [22].

Battery hours used per day based on 4 hours /day =  $4 \times 68320 = 273,280$  kWh/day

$$\text{Nominal battery voltage} = 48 \text{ V Battery capacity (Ah)} = \frac{\text{Total watt hours per day} \times \text{days of autonomy}}{0.85 \times 0.6 \times \text{nominal battery voltage}} \quad (5)$$

Capacity is equivalent to  $(11163 \times 10^3 \times 48) / 10^3 = 535,824$  kWh  $\cong$  536 MWh

No. of batteries required =  $11163 \times 10^3 / 860 = 12,980$

With an initial state of full charge, the battery can produce 134 MW for 4 hours before SOC decrease below 50%. On

the other hand, part of PV plant dedicated to batteries charging is estimated to produce 355 MWh/day. With an initial SOC of 60 %, the battery can store 321 MWh. of electricity, which is 90% electricity of PV plant in a daily cycle. The 12,980 batteries will be placed in battery enclosures located alongside the 12 stations.

#### 4.1.8. Civil Design Aspects

Civil aspects of slab track design are not in the scope of this paper. The only additional civil work required, is the 1.2 m extension of the reinforced concrete track bed on either end to accommodate the PV panels (see Figure 1).

### 5. Project Costs

The economic aspects of the plant will depend on the over-night construction costs of the project, the levelized electricity costs, and the capacity factor.

#### 5.1. Overnight Construction Costs

These are the capital cost of the project if it could be built overnight. The civil and equipment cost of Solar plant are approximate and based on the prevailing rates. Prices for solar, based on Fu et al. (2017) studies [23]. As shown in Table3, the total cost of Solar plant, Csp is \$525 million.

##### 5.1.1. Contingency Cost

Refers to costs that will probably occur based on past experience, but with some uncertainty regarding the amount. Most projects use a rate of 5-10% from the total budget to determine contingency [24]. The present project is based on PV solar and battery storage technology, which are well established. Also, project estimation is based on the latest prevailing rates. Hence, a figure of 5% is taken. Then, total cost of Solar plant Csp = \$ (525 + 26.25)10<sup>6</sup> ≅ \$ 552 million.

Total power = Power from PV plant + Power from battery bank

Then Pc = (191.69 + 134)×10<sup>3</sup> = 325.69×10<sup>3</sup> kW, ≅ 330 MW

Overnight construction cost = Csp / Pc = 552×10<sup>6</sup>/ 330 = \$ 1.67×10<sup>6</sup> /MW

**Table 3. Cost break-up of Solar Plant**

Description	USD million
Concrete, 15,000 m <sup>3</sup> @ \$600 / m <sup>3</sup>	90.00
Utility scale PV fixed tilt solar plant, (Includes, solar modules, BOS electrical, Racking and inverters) 191.68 x 10 <sup>6</sup> W @ \$ 1.03/W	197.44
Batteries 12,980 no @ \$ 5,384	69.88
Battery replacement @ 180 %	<u>125.69</u>
Sub- total	483.01
Transportation & erection @ 8%	<u>38.64</u>
Sub- total	521.65
Design and planning	3.0
Cost of Solar plant Csp	524.25 ≅ \$ 525

#### 5.2. Capacity Factor

Capacity factor (CF) is important in the determination of the Solar PV plants, Economics and is given by;

$$CF = \frac{\text{Annual kWh generated for each kW peak capacity}}{8760 \text{ hrs per year}} \quad (6)$$

Annual generation = (1065.792) 10<sup>3</sup>×365 = 389,048×10<sup>3</sup> kWh

Peak capacity requirement = 191,689×10<sup>3</sup> kW,

Then annual kWh generated for each kW peak capacity =389,014,000 /191,689,000 =2,029 kWh

CF = 2029/8760 = 0.23 or 23 %

#### 5.3. Levelized Electricity Costs

The levelized electricity costs represent the generating costs after initial investments. Economic projections on

complex hybrid systems utilizing different technologies is challenging and no correct design method is available for guiding decision makers [25]. For this example, numerical analysis for cost of renewable energy is based on NREL [26] tool (CREST) Version 1.4. Input data used are indicated in Table 4. Fixed operation and maintenance (O&M) costs taken as \$6.5/kW/yr. Based on this analysis, the Output Summary indicates that the Net Nominal Levelized Cost of Energy is 12.05 c/kWh.

**Table 4. Input Summaries for LCOE**

Generator Name plate capacity kW	330,000
Net Capacity Factor Yr. 1 %	23%
Production Yr. 1 kWh	486,834,000
Project useful life Years	25
Payment Duration Years	25
Net Installed Cost \$	552,000,000
Net Installed Cost \$/Watt	1.67
O&M Cost \$/kW/yr.	6.5
Equity %	70%
Target after tax equity IRR %	8%
Debt %	30%
Debt term Years	18
Interest rate on term debt %	6%

**5.4. Financial Analysis**

Results of financial analysis considering plant life of 25 years; Pretax (Cash only) Equity IRR (over defined useful life) is 6.46 %. Pretax Equity IRR (over defined useful life) is 8.00 %. NPV @ 8% (over defined useful life)= \$1,538,000, and simple payback period 11 years.

By way of cost saving, it can be shown that total annual energy production from PV plant and BESS =  $(389,014 \times 10^3 + 268,000 \times 365) = 486,834 \times 10^3$  kWh. Tariff charged by Maharashtra Government for railway traction [27], are Rs 7.81/kWh. (12 \$c/kWh). Then, after payback period of 11 years, the net saving in tariff per annum will =  $12 \times 486,834,000 = 5,842,008 \times 10^3$  \$c or \$ 58.42 million (Rs 377 crores).

This case study should only be considered as an example of the methodology, as the findings are qualitative in nature and are intended as a guide to current thinking and attitudes rather than as a robust data source. Future work is needed to evaluate representative locations in each region of the country as demarcated by solar insolation and electricity prices. An optimized solution for the design of a complete track section along with calculations and evaluation of the cost function would follow the procedure as shown in Figure 5.

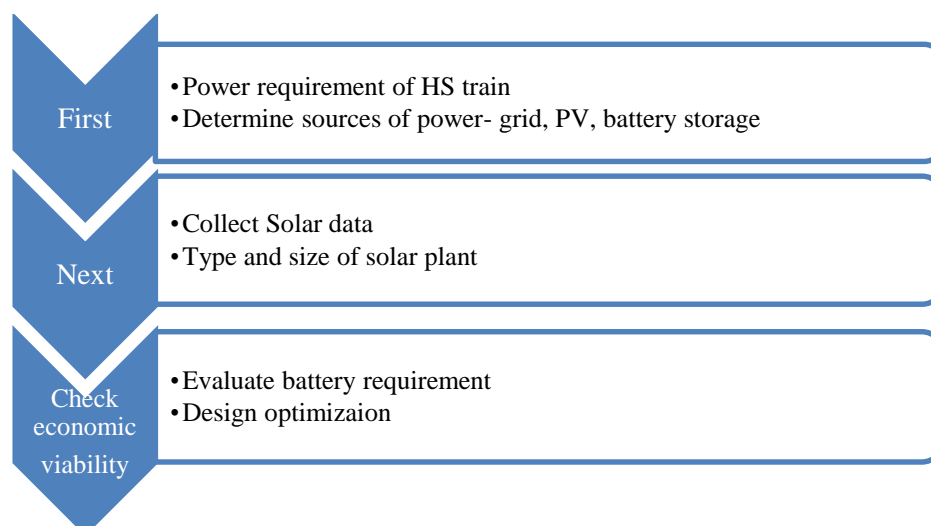

**Figure 5. Flow chart of the design optimization**



## 6. Results and Discussions

### 6.1. Construction Costs

It can be concluded that the technology has low investment construction costs. This is mainly because land and transmission costs are minimal. However, even this price will continuously drop over the years with increased installed capacity, as a result of technological improvements, economics of scale and volume production. As an example, historical pricing trends for solar power systems indicate that the cost-per-watt (system) dropped from \$12.36 in 1998 to \$3.13 in 2017 [28]. Batteries are a significant expense, and Li-ion costs have dropped from \$ 1000/kWh in 2010 to about \$200/kWh, a drop of 80% in 8 years [29].

### 6.2. Cost Comparison

Table 5 presents typical average total installed costs and LCOE of utility- scale. Renewable Power Generation US Dept. of Energy [30]. It can be seen that the present technologies are now within the same cost range of other renewable power technologies and even lower than for off-shore wind.

**Table 5. Typical average Installed costs and LCOE of Utility scale Renewable Power Generation [29]**

Plant Characteristics	Average Installed Cost USD/kW	Average LCOE USD/kWh
Solar PV	2330	0.08
Bio-mass power station	4300	0.04 to 0.14214
On-shore wind	2000	0.06
Off-shore wind	4500	0.1 to 0.17
Concentrated solar power	6740	0.17
Hydropower	1000 to 3500	0.02 to 0.15
Solar PV plus Battery for HS traction	1670	0.12

### 6.3. Scale Up

The length of operational HS lines in the world exceeding 250 kmph is about 42,776 km [31]. Adopting this technology would to a large extent help in bringing down the operational costs of these HS trains.

### 6.4. Clean Energy

Renewable energy technologies provide an excellent opportunity for mitigation of greenhouse gas emissions and reduce global warming, [32]. It is estimated that 300 kg of CO<sub>2</sub> could be avoided for each MWh generated by renewable energy, [33]. Thus, clean energy from the present plant could effectively prevent 146,050 tonnes of CO<sub>2</sub> entering the atmosphere.

## 7. Conclusion

A study has been carried out to assess the technical feasibility and economic viability of a grid connected solar PV plant for meeting the energy demands of traction for a HS railway track. The approach taken in this concept study has been driven by the fact that ballast less tracks require little or no maintenance. It has been shown that the space between tracks provides a large surface area on which arrays of PV modules can be mounted to generate electricity from sunlight, so that the ballast-less tracks could be used as energy carriers. The intermittent nature of the renewable energy sources are combined with a battery energy storage system. An example is given of an on-site solar PV plant cum battery storage of 330 MW capacities to supply energy to the HS trains planned between Mumbai and Ahmedabad. Annual electricity generation of the plant is 486,834 MWh and levelized cost of electricity is 12.05 c/kWh, considering 25 years plant life. For a track length of 221 km, the annual saving in energy bill is approximately \$58 million. Thus, this design is committed to developing an environmentally and economically sustainable long term alternative to the current high speed rail transportation system which would rely predominantly on clean energy.

## 8. Conflicts of Interest

The authors declare no conflict of interest.

## 9. References

- [1] Hayashiya, Hitoshi, Hiroshi Itagaki, Yuichi Morita, Yoshihisa Mitoma, Takayuki Furukawa, Takuya Kuraoka, Yuta Fukasawa, and Takatoshi Oikawa. "Potentials, Peculiarities and Prospects of Solar Power Generation on the Railway Premises." 2012 International Conference on Renewable Energy Research and Applications (ICRERA) (November 2012). doi:10.1109/icrera.2012.6477458.

- [2] Shen, X. J, Y. Zhang, and Sh. Chen. "Investigation of Grid-Connected Photovoltaic Generation System Applied for Urban Rail Transit Energy-Savings." 2012 IEEE Industry Applications Society Annual Meeting (October 2012). doi:10.1109/ias.2012.6373995.
- [3] Shravanth Vasisht, M., G.A. Vashista, J. Srinivasan, and Sheela K. Ramasesha. "Rail Coaches with Rooftop Solar Photovoltaic Systems: A Feasibility Study." *Energy* 118 (January 2017): 684–691. doi:10.1016/j.energy.2016.10.103.
- [4] Ciccarelli, Flavio, Luigi Di Noia, and Renato Rizzo. "Integration of Photovoltaic Plants and Supercapacitors in Tramway Power Systems." *Energies* 11, no. 2 (February 9, 2018): 410. doi:10.3390/en11020410.
- [5] Mike Chino, "220MPH Solar-Powered Bullet Train on Arizona Horizon" (2009). <https://inhabitat.com/transportation-tuesday-arizona-startup-unveils-solar-bullet-train/>.
- [6] Smriti Jain, "India's 'first solar-powered train': All you want to know about Indian Railways' green initiative", *Financial Express*, (2016). <https://www.financialexpress.com/economy/indias-first-solar-powered-train-all-you-want-to-know-about-indian-railways-green-initiative/264505/> (Accessed 2017)
- [7] Esveld, Coenraad. "Modern Railway Track, 2nd Edition." Delft university of Technology (2001).
- [8] Mumbai-Ahmedabad HS Corridor (2017). <http://en.wikipedia.org/wiki/Mumbai> (Accessed 2017).
- [9] Hayashiya, Hitoshi, Shoji Yokokawa, Yuki Iino, Shinya Kikuchi, Takashi Suzuki, Shoji Uematsu, Naomi Sato, and Toshihiko Usui. "Regenerative Energy Utilization in A.c. Traction Power Supply System." 2016 IEEE International Power Electronics and Motion Control Conference (PEMC) (September 2016). doi:10.1109/epepemc.2016.7752152.
- [10] Nagaura, Yasuhiro, Ryoichi Oishi, Motomi Shimada, and Takashi Kaneko. "Battery-powered Drive Systems: Latest Technologies and Outlook." *Hitachi Review* 66, no. 2 (2017): 139.
- [11] Giannakos, K. "Requirements of tomorrow's rail transport infrastructure." In 2nd Traffic and Transportation Conference, Vossloh AG, Berlin, Germany, vol. 20. 2004.
- [12] Agarwal M.M., Miglani K.K, "Challenges and possible solutions for appropriate track technologies of semi high speeds & heavy axle loads based on global experience", *The Institute of Permanent Way Engineers Seminars*, (2017).
- [13] Franz, Q. "Innovative Track Systems Technical Construction." Project funded by the European Community, Directorate General Energy and Transport Under the 'Competitive and Sustainable Growth' Programme. ProMain. TÜV Intertraffic, Cologne (2001).
- [14] He, Zhengyou, Zheng Zheng, and Haitao Hu. "Power Quality in High-Speed Railway Systems." *International Journal of Rail Transportation* 4, no. 2 (April 2, 2016): 71–97. doi:10.1080/23248378.2016.1169228.
- [15] Takatsu T, "Mumbai-Ahmedabad High Speed Railway Corridor", (2013). Accessed on: [www.jterc.or.jp/koku/koku\\_semina/pdf/130211-jic-presentation.pdf](http://www.jterc.or.jp/koku/koku_semina/pdf/130211-jic-presentation.pdf).
- [16] "Joint Feasibility Study for Mumbai-Ahmedabad High Speed Railway Corridor", Final Report. Japan International Cooperation Agency (JICA), Ministry of Railways, Republic of India (MOR), (2015).
- [17] "How to Design Solar PV System Guide for sizing your solar photovoltaic system", (2015). Accessed on: [http://www.leonics.com/support/article2\\_12j/articles2\\_12j\\_en.php](http://www.leonics.com/support/article2_12j/articles2_12j_en.php).
- [18] India Solar Resources, Accessed on: [www.nrel.gov/international/images/dni\\_annual.jpg](http://www.nrel.gov/international/images/dni_annual.jpg).
- [19] Hagiwara, Yoshiyasu. "Environmentally-Friendly Aspects and Innovative Lightweight Traction System Technologies of the Shinkansen High-Speed EMUs." *IEEJ Transactions on Electrical and Electronic Engineering* 3, no. 2 (2008): 176–182. doi:10.1002/tee.20253.
- [20] Solarland Model SLP1905-24 Silver Mono Solar panel, (2016). <http://www.wholesolar.com/9433270/solarland-slp1905-24-silver-mono-solar-panel> (Accessed 2017).
- [21] Affordable solar, (2016). [http://www.affordable-solar.com/store/...sma\\_inverters/sma-sunny-central-500U-inverter](http://www.affordable-solar.com/store/...sma_inverters/sma-sunny-central-500U-inverter) (Accessed 2016).
- [22] Wholesale solar, (2016). [www.wholesolar.com/brands/crown](http://www.wholesolar.com/brands/crown) (Accessed 2017).
- [23] Fu, Ran, David Feldman, Robert Margolis, Mike Woodhouse, and Kristen Ardani. "U.S. Solar Photovoltaic System Cost Benchmark: Q1 2017" (September 1, 2017). doi:10.2172/1395932.
- [24] Crompton Construction, (2015). <http://comptonllc.com/contingency-budgets/> (Accessed 2018).
- [25] Mundada, Aishwarya S., Kunal K. Shah, and J.M. Pearce. "Levelized Cost of Electricity for Solar Photovoltaic, Battery and Cogen Hybrid Systems." *Renewable and Sustainable Energy Reviews* 57 (May 2016): 692–703. doi:10.1016/j.rser.2015.12.084.
- [26] NREL, (2017). <https://financere.nrel.gov/finance/content/crest-cost-energy-m> (Accessed 2018).

- [27] Railway traction, [www.mahadiscom.com/tariff/Tariff-Booklet-aug-2012.pdf](http://www.mahadiscom.com/tariff/Tariff-Booklet-aug-2012.pdf) (Accessed 2018)
- [28] “Solar Panel Cost Guide | Your complete guide to the cost of Solar in 2019”, <https://www.wholesalesolar.com/blog/solar-panel-cost-guide/> (Accessed 2019)
- [29] Cost of Li-ion Batteries, <http://www.eai.in/blog/2018/12/cost-of-batteries.html> (Accessed 2019)
- [30] EIA, US. "Updated capital cost estimates for utility scale electricity generating plants." US Energy Inf. Adm 524 (2013).
- [31] <https://www.worldatlas.com/articles/countries-with-the-most-high-speed-rail.html>
- [32] Panwar, N.L., S.C. Kaushik, and Surendra Kothari. “Role of Renewable Energy Sources in Environmental Protection: A Review.” *Renewable and Sustainable Energy Reviews* 15, no. 3 (April 2011): 1513–1524. doi:10.1016/j.rser.2010.11.037.
- [33] International Energy Agency (2010)], *Implementing Agreement on ocean energysystems, Annual Report 2010.* [http://www.wavec.org/client/files/2010\\_Annual\\_Report.pdf](http://www.wavec.org/client/files/2010_Annual_Report.pdf) (Accessed 2017).